

FORD

OPERATING AND ASSEMBLY INSTRUCTIONS

DEARBORN

SIDE MOUNTED MOWER

MODEL 14-233

**COMPONENT
NO.**

14-61 Five Foot Cutter Bar

14-64 Six Foot Cutter Bar

14-234 Seven Foot Cutter Bar

TRACTOR AND IMPLEMENT DIVISION

Ford Motor Company

BIRMINGHAM, MICHIGAN

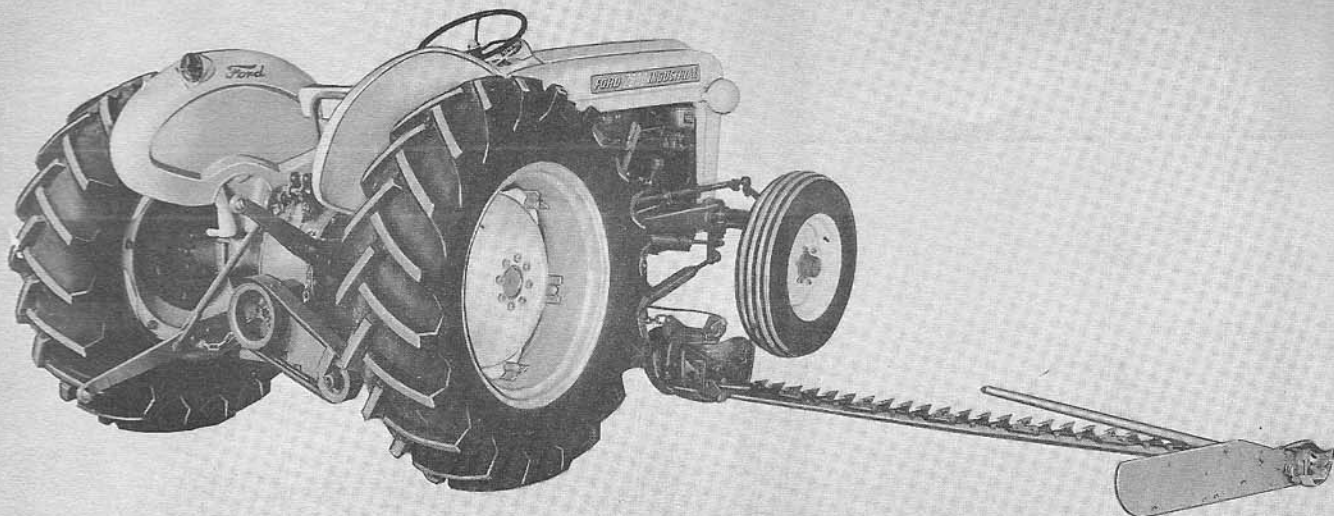

Figure 1
Dearborn Side Mounted Mower Installed

GENERAL

The Model 14-233 Dearborn Side Mounted Mower, Figure 1, is a heavy duty implement well suited for both farm and industrial use. The mower is sturdily constructed and is designed for use with either Series 600, 601, 800, 801, 2000, and 4000 Ford Tractors having a P.T.O. and a hydraulic lift. This mower can be used with a gearshift type or Select-O-Speed Transmission.

This heavy duty mower is specially designed for cutting heavy hay and other mowable vegetation and for mowing highway shoulders, rights-of-way, and other industrial applications. It will operate efficiently with the cutter bar at any angle from 45° below horizontal to almost vertical. This feature makes it desirable for cutting steep highway banks and slopes. The free floating action of the cutter bar permits close operating positions along the contour of the ground.

Cutter Bar Assemblies are available in five, six, and seven foot sizes as Component Nos. 14-61, 14-64, and 14-234 respectively. All models are equipped with heavy duty rock guards. The Ford Tractor Hydraulic System enables the operator to raise the mower to transport position from the tractor seat. This mower is equipped with a curb lift lever to carry the inner shoe above ground level for mowing over curbs and slight elevations. A screw-type cutter

bar tilt adjustment is standard equipment while a tilt lever, Figure 11, is available as extra equipment. Both levers are readily accessible from the tractor seat and enable the operator to quickly adjust the cutter bar to meet various mowing conditions. A safety switch is also provided which automatically stops the tractor when the cutter bar strikes an obstruction, thus preventing damage to the mower and tractor.

This manual contains information on the operation, assembly, lubrication, and adjustment of your Dearborn Side Mounted Mower. Read it carefully and keep it available for ready reference.

OPERATION

The Model 14-233 Side Mounted Mower is designed to handle heavy duty as well as general mowing. With a little experience and by applying the information in this manual, the operator should be able to make the implement perform with desired efficiency.

Before attempting to operate the mower, place the tractor hydraulic control selector lever in "Position Control" (up position). With the selector lever in this position, the cutter bar may be lowered or raised, easily and quickly, with the tractor hydraulic touch

OPERATION

control lever. This facilitates clearing small obstructions as well as backing into corners, and up to fence rows.

The mower is equipped with a curb lift lever (1), Figure 7, to enable the operator to raise the cutter bar with the tractor hydraulic system and set the operating height of the inner shoe without leaving the tractor seat.

To lower the cutter bar from the transport position, move the tractor touch control lever to the full "UP" position. Unhook the safety chain from the inner shoe and release the curb lift lever. Slowly move the tractor touch control lever downward until the cutter bar contacts the ground. Set the P.T.O. speed at 545 rpm and shift the gearshift lever in the position best suited for the job. In some instances, it will be more desirable to lower the engine rpm while operating in tight places rather than to downshift. When very heavy cutting is encountered, it may be necessary to

operate the tractor in first gear; however, the use of second or third gear will be satisfactory in most instances.

NOTE: For best results, do not operate the mower above a P.T.O. speed of 545 rpm.

To raise the cutter bar to transport position, disengage the P.T.O. and slowly raise the tractor touch control lever all the way up. Attach the safety chain to the inner shoe. Lower the touch control lever slowly until all slack has been removed from the safety chain.

Before taking the mower into the field, it is recommended that it be given the over-all check indicated on page 4. To obtain the longest service and the most efficient operation, adhere closely to the following information on lubrication, adjustment, and maintenance.

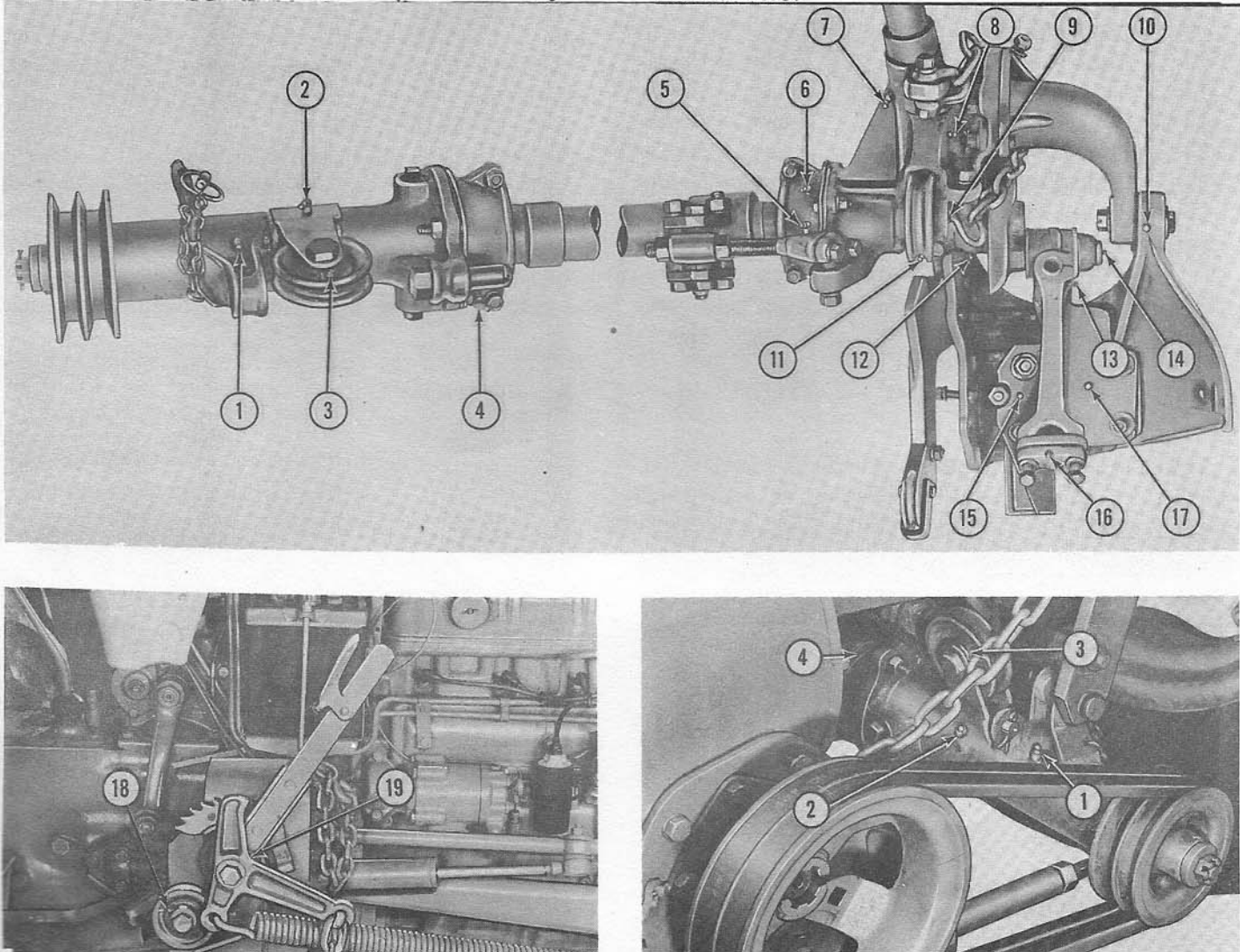

Figure 2
Lubrication Points

LUBRICATION

There are nineteen lubrication fittings on the Model 14-233 Dearborn Side Mounted Mower. The location of these fittings is listed as follows:

Fitting No.	Location	Lubricate
1	Pulley Housing	Every 48 Hours
2	Cable Sheave Bracket	Every 4 Hours
3	Cable Sheave (Pulley Housing)	Every 4 Hours
4	Rear U-joint Housing	Every 4 Hours
5	Tilt Link (Front).....	Every 4 Hours
6	Front U-joint Housing	Every 4 Hours
7	Hinge Assembly Drag Bar Socket	Every 4 Hours
8	Cable Sheave Bracket	Every 4 Hours
9	Cable Sheave	Every 4 Hours
10	Hinge Assembly.....	Every 4 Hours
11	Inner Shoe Cap.....	Every 4 Hours
12	Crankshaft Housing.....	Every 4 Hours
13	Pitman Box & Bushing.....	Every 2 Hours
14	Pitman Bearing Cap	Every 4 Hours
15	Pitman Ball Cap.....	Every 2 Hours
16	Knife Guide Assembly - Front	Every 2 Hours
17	Cable Sheave	Every 4 Hours
18	Counter Balance Lever	Every 4 Hours
19	Knife Guide Assembly - Rear	Every 2 Hours

The front universal joint (6), Figure 2, and the rear universal joint (4) on the mower drive shaft, are packed with SAE 160 lubricant at the factory and should be checked once a year.

Lubricate the knife hold-down clips frequently with a good grade of engine oil.

FINAL CHECK BEFORE FIELD OPERATION

After the mower has been assembled on the tractor, proceed as follows:

1. Check the mower to make certain that it has been properly lubricated as detailed in the Lubrication section of this manual.
2. The cutter bar lead is built into the mower and is controlled by the pull spring. Adjust the pull

spring as required, to just hold the cutter bar against the stop for normal mowing.

3. Set the cutter bar weight for the proper ground pressure as detailed under the Front Balance Spring and Drag Bar Balance Spring Adjustments on page 5.
4. Lower the cutter bar and start the tractor engine. Engage the tractor P.T.O. and set the speed at approximately 545 rpm. Allow the cutter to operate for approximately 1/2 hour for a break-in period, then disengage the P.T.O. and shut off the tractor engine. Examine the blade for hot spots and make the necessary adjustments as detailed below.
5. Check all mower attaching bolts for looseness and tighten as required.

ADJUSTMENTS

Knife Guards: Align the guards (5), Figure 3; by striking the forward end up or down with a hammer until the ledger plates (6) are flush with the knife sections (2). The knife guard lip (1) should be above the knife clips (3) and kept straight as shown.

NOTE: *Align the guards before attempting to adjust the knife clips.*

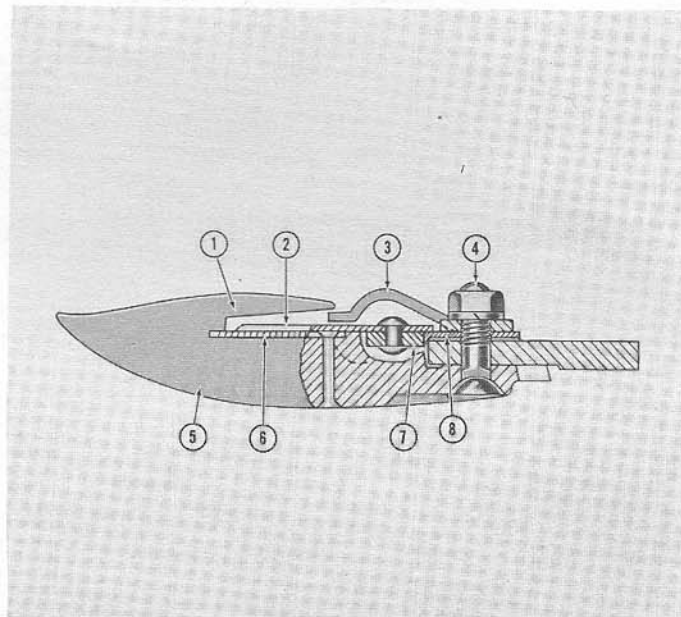

Figure 3
Cross Sectional View of Cutter Bar

Knife Clips: The knife clips (3), Figure 3, should hold the knife sections down on the ledger plate (6), without binding the knife sections. To reduce knife clip clearance, strike the forward end of the knife clip with a hammer. If the clip is bearing too hard on the knife, strike the flat surface of the clip between the two bolts (4), Figure 3, to increase the clearance. Remove the knife before striking the clips.

Wear Plates: The wear plates (8), Figure 3, located under each knife clip (3), must fit snugly against the knife back (7) as shown, and yet have sufficient clearance to avoid binding. To adjust the wear plates, loosen the nuts on the two bolts (4). Tap the wear plates forward against the knife back and tighten the nuts securely.

Guide Plates: To avoid slap or vertical play in the knife, remove the nuts (8) and (10), Figure 4, from the guide plates (12) and (14). Remove shims from under each guide plate until the knife head has no more than 1/32" vertical play and the knife slides freely. When replacing the rear guide plate (14), position the wear plate (13) so that it almost touches the back of the knife head (15). This will eliminate side play at the knife head.

Knife Register: Proper knife register is an important factor in efficient mower operation. When properly adjusted, the knife stroke should be equalized between

the knife guards as shown in Diagram A, Figure 5, when the Pitman arm is at either end of its stroke. If the knife sections are out of register, see Diagram B, Figure 5, correct the condition by adding or removing washers (2), Figure 6, from between the Pitman yoke (1) and the socket (3).

NOTE: This check or adjustment is not necessary on new mowers.

Pitman Rod Socket Joints: To compensate for wear on the knife head ball, adjust by removing the metal shims (4), Figure 6, from between the halves of the socket joint. This joint must be checked and carefully adjusted periodically. If too tight, it will quickly overheat and tend to lift the knife head vertically. If too loose, breakage may result.

IMPORTANT: If the paint discolors at the joint, it can be considered too tight.

Pull Spring: The cutter bar lead is built in and is 3/8" per foot of cutter bar. To maintain the proper lead, turn the adjusting bolt (14), Figure 7, into the pull spring (13) to hold the cutter bar against the stop, but not tight enough to exceed breakaway conditions.

Drag Bar Balance Spring: Turn the adjusting bolt

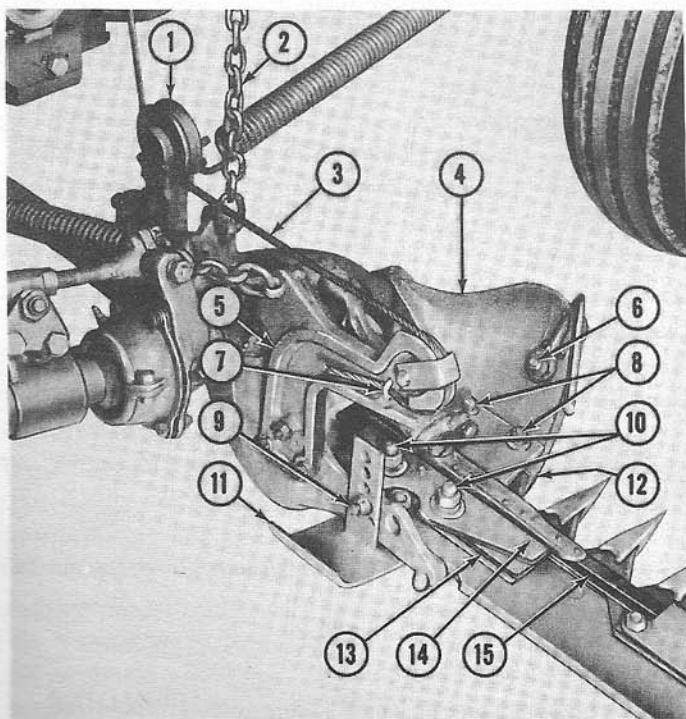

Figure 4
Cutter Bar Attached to Inner Shoe

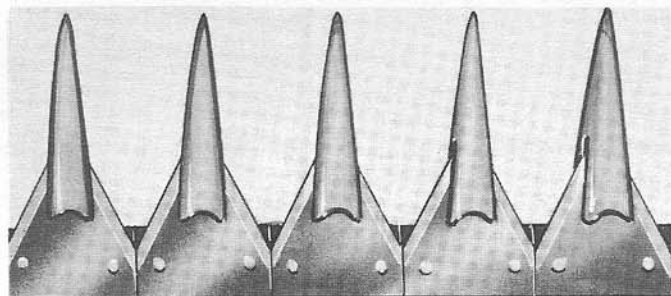

DIAGRAM A

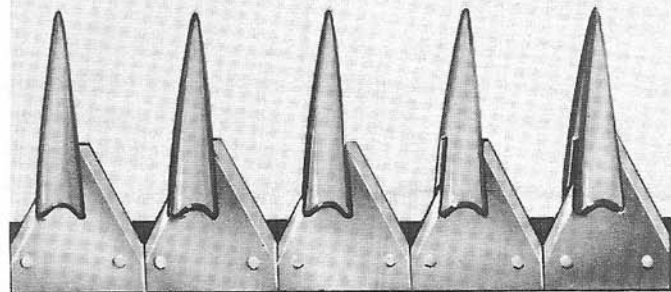

DIAGRAM B

Figure 5
Knife Register

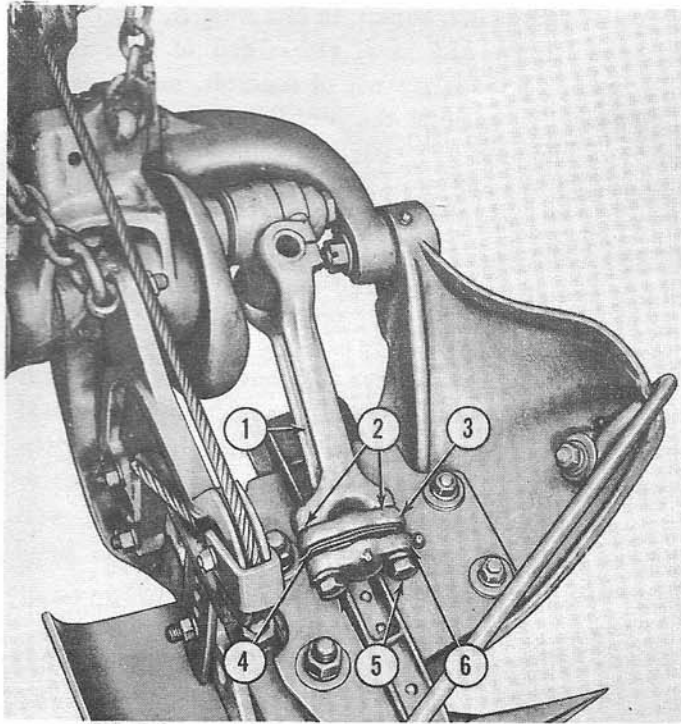

Figure 6
Pitman Rod Shims

(16), Figure 7, into the drag bar balance spring (17) until the outer shoe ground pressure is approximately 15 lbs. or until the outer end of the cutter bar can be raised easily with one hand. Secure the adjusting bolt with the lock nut. Proper balance spring adjustment will produce a semi-floating cutter bar which will slide easily over the ground without excessive sole wear.

Front Balance Spring: Turn the adjusting bolt (8), Figure 7, into the front balance spring (6) until the ground pressure on the inner shoe is approximately 50 lbs. Secure the adjusting bolt with the lock nut. With this setting, the inner shoe should be in contact with the ground and a semi-floating cutter bar should be maintained.

Belt Tension: To adjust the tension on the mower V-belts, loosen the lock nut and turn the adjusting sleeve until there is approximately 1/4" free play in the belts midway between the sheaves, Figure 8. Secure the adjusting sleeve with the lock nut. Worn V-belts should be replaced in pairs.

Height of Cut: The height of cut is controlled by the position of the inner and outer shoes. For uniform cutting, adjust both shoes alike. To adjust the cutter

bar at the outer shoe, remove the bolt (10), Figure 9, raise or lower the shoe to the desired position on the shoe sole (9), and secure with the bolt, lock washer, and nut.

To adjust the cutter bar at the inner shoe, remove the bolt (9), Figure 4, raise or lower the shoe as desired on the shoe sole (11), and secure with the lock washer and nut. For best results, be sure the cutter bar is set to a uniform height at both the inner and outer shoes.

Curb Lift Lever: The curb lift lever (1), Figure 7, is used to maintain the operating height of the inner shoe to permit mowing at a level above that on which the tractor is traveling.

Mower Safety Switch: The Dearborn Side Mounted Mower is provided with a safety switch which automatically cuts the tractor ignition when the mower cutter bar contacts an obstruction. The cutter bar then breaks back, absorbing the shock until the tractor stops to protect the tractor and the mower. To resume operation, disengage the P.T.O., press the push button, and start the tractor engine. Continue to hold the push button in and back the tractor slowly until the cutter bar returns and locks in its former position. Release the button, engage the P.T.O., raise the mower over the obstruction, and resume mowing.

Cutter Bar Tilt: A tilt mechanism is provided as standard equipment, Figure 10, to tilt the leading edge of the cutter bar up or down for various mowing conditions. For example: When mowing in stoney fields, the points of the guards should be raised. When mowing smooth, even fields, the points of the guards should be close to the ground. To tilt the cutter bar down, loosen the nut (2), Figure 10, as required, and tighten the nut (1) against the pivot (5) to move the cutter bar downward. To raise the cutter bar, loosen nut (1) and tighten nut (2). If the mower has a tilt lever (optional equipment), Figure 11, the lever must be moved forward to move the cutter bar down or back to raise the cutter bar.

Under normal operating conditions, the cutter bar should be run level.

KNIFE AND CUTTER BAR MAINTENANCE

Excessive Side Draft: Tractor side draft is an in-

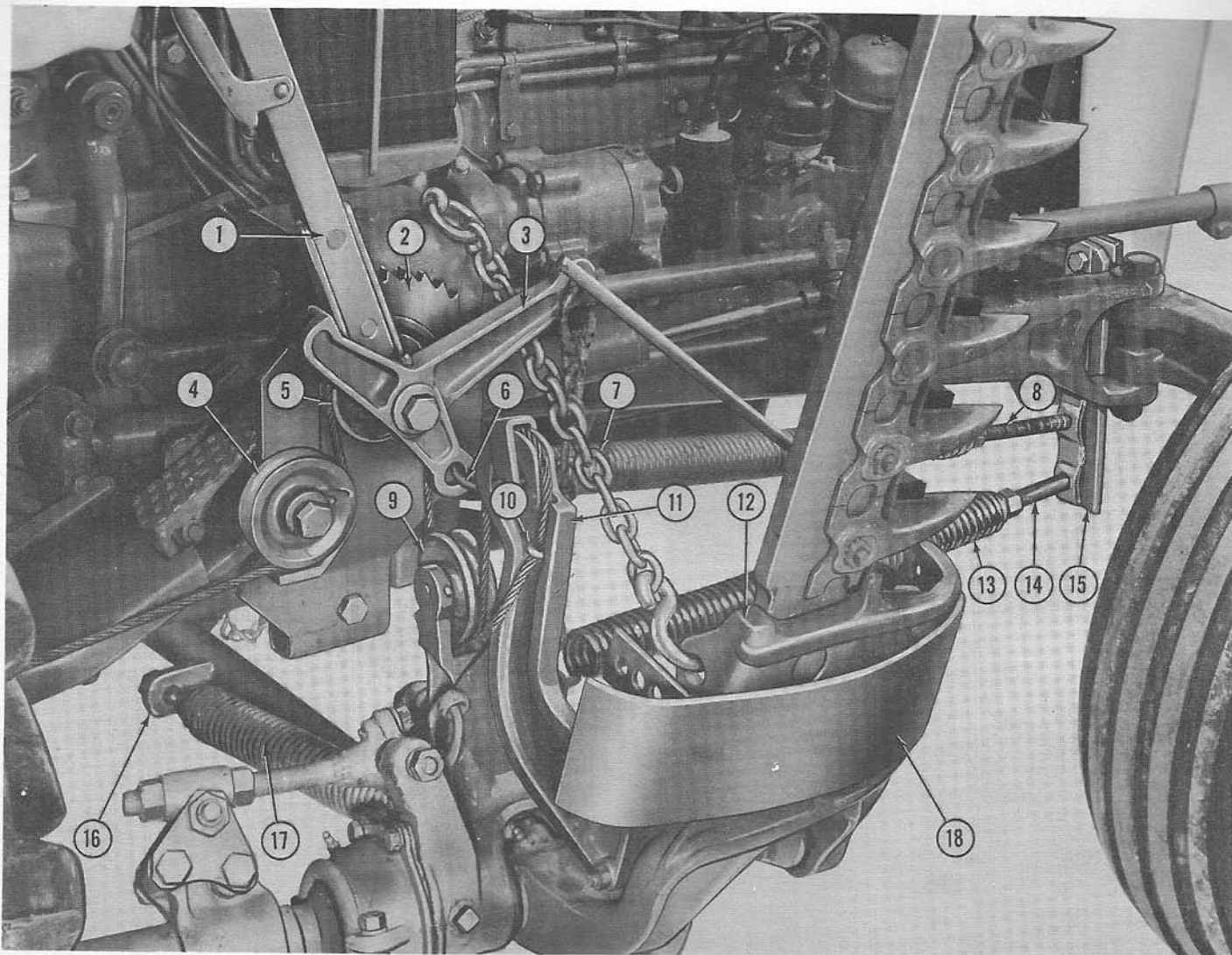

Figure 7
Mower Springs and Lift Lever Attached

dication of mower malfunction. To find the source of trouble, check for worn ledger plates, bent guards, dull knife, improperly sharpened knife or bent knife clips.

Knife Breakage: Often, knife breakage is caused by loose parts and improper adjustment. Be certain that the entire mower is properly adjusted and that all connections are tightened securely.

Ragged Cutting: A worn, broken, or dull knife, worn or broken ledger plates, uneven shoe adjustment, loose knife sections, knife out of register, bent or broken knife guards will cause ragged cutting.

Removing Knife Sections: To remove the knife sections from the knife back, place the section loosely

in a vise, with the knife back resting on the vise jaw as shown in Figure 12. Strike the back of the section with a hammer to shear the rivets. Drive the sheared rivets out of the knife back with a metal punch.

Installing Knife Sections: Remove the knife from the mower and remove the broken sections as outlined above. Position the knife section and two rivets on the knife back and place this assembly on a solid surface with the rivet heads down to hold them in place. Strike the rivets with a rivet set and check to be sure the section is as tight as possible. Repeat this procedure until all sections have been replaced.

Replacing Ledger Plates: Ledger plates should be replaced if the edges become worn. Dull ledger plates cause ragged cutting and side draft.

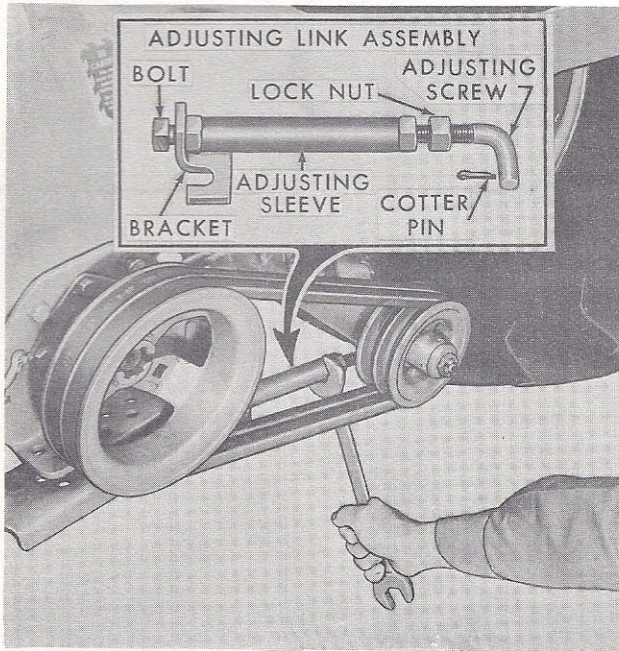

Figure 8
Belt Adjustment

TRANSPORTING THE MOWER

To put the side mounted mower in transport position, disengage the P.T.O. and then raise the cutter bar to a vertical position, Figure 7, with the Ford Tractor Hydraulic Touch Control Lever. Connect the safety chain in the hole on the inner shoe (12) as shown in Figure 7. Slowly lower the touch control lever until all slack is removed from the safety chain.

ATTACHING MOWER TO TRACTOR

1. Position the mower assembly on the ground as

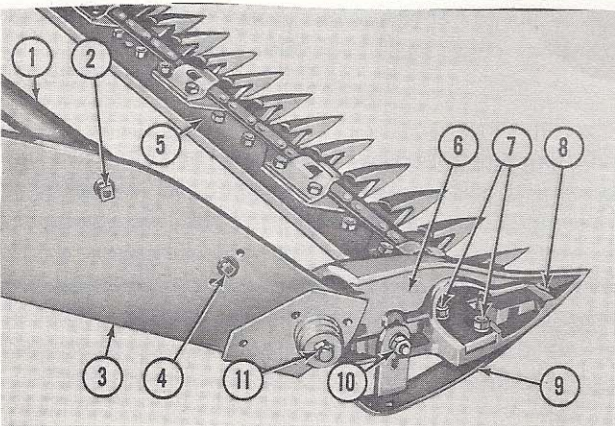

Figure 9
Outer Shoe and Swathboard Installed

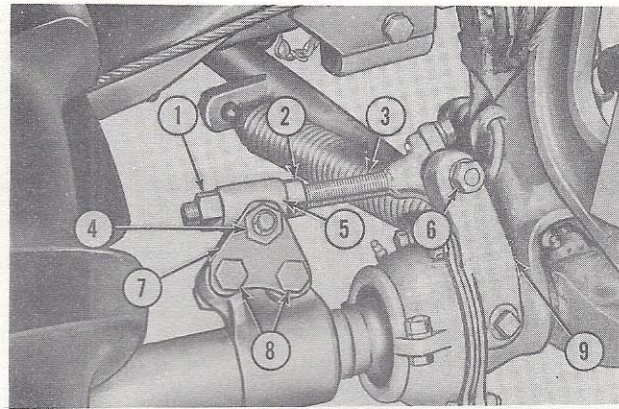

Figure 10
Cutter Bar Tilt Adjustment

shown in Figure 13, with the drive shaft (1), as far to the left as possible, and place one foot 2" x 4"s (3) on each side of the drag bar (2).

2. Drive the tractor right front wheel over the drag bar at the 2" x 4"s, and stop when the mower sheave is below the tractor right rear axle. Attach the drive housing to the right axle bracket, using the pin and linch pin provided.
3. Attach the drag bar (7), Figure 14, to the left frame assembly (9).

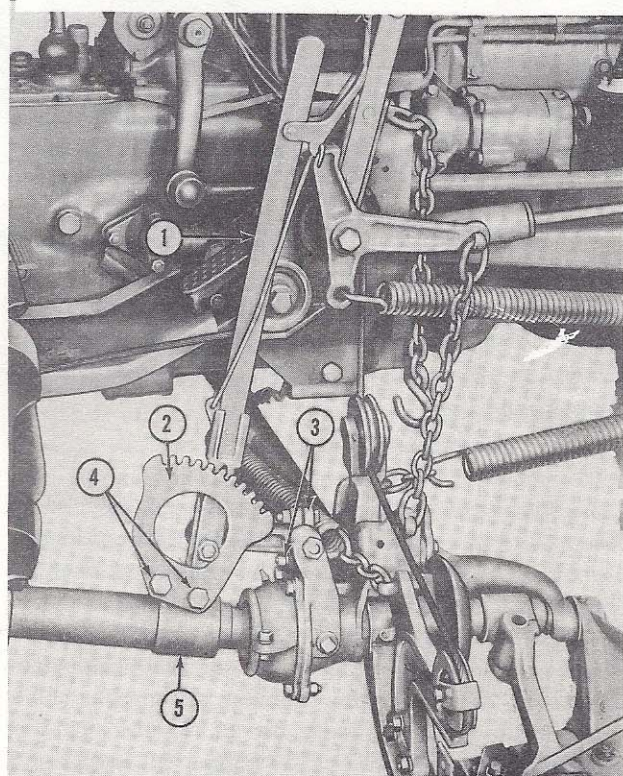

Figure 11
Tilt Lever Installed

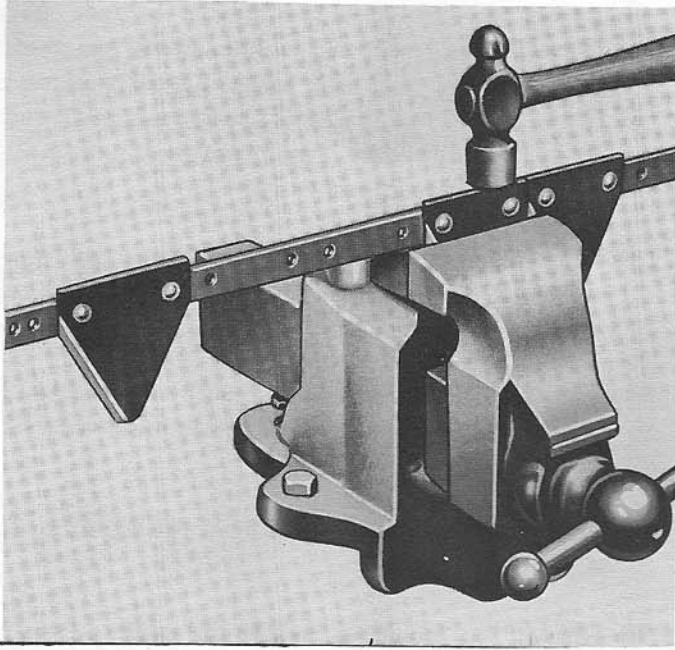

Figure 12
Removing Knife Sections

4. Attach the safety switch chain (6) to the drag-bar (7).
5. Secure the axle clamp (15) to the axle as shown in Figure 7. Hook the balance spring (6) on the curb lift arm (3) with the hook toward the tractor. Thread bolt (8) into the balance spring until the coils start to open. Hook the pull spring (11), Figure 15, into chain (10) and thread the bolt into it until the desired tension is obtained.
6. Attach the curb lift chain (4), Figure 15, to the curb lift lever (3) and secure with the lock washer and nut.
7. Raise the outer end of the cutter bar by hand and hook the short chain (7), Figure 15, to the drag bar balance spring (5) and lower the cutter bar to the ground.

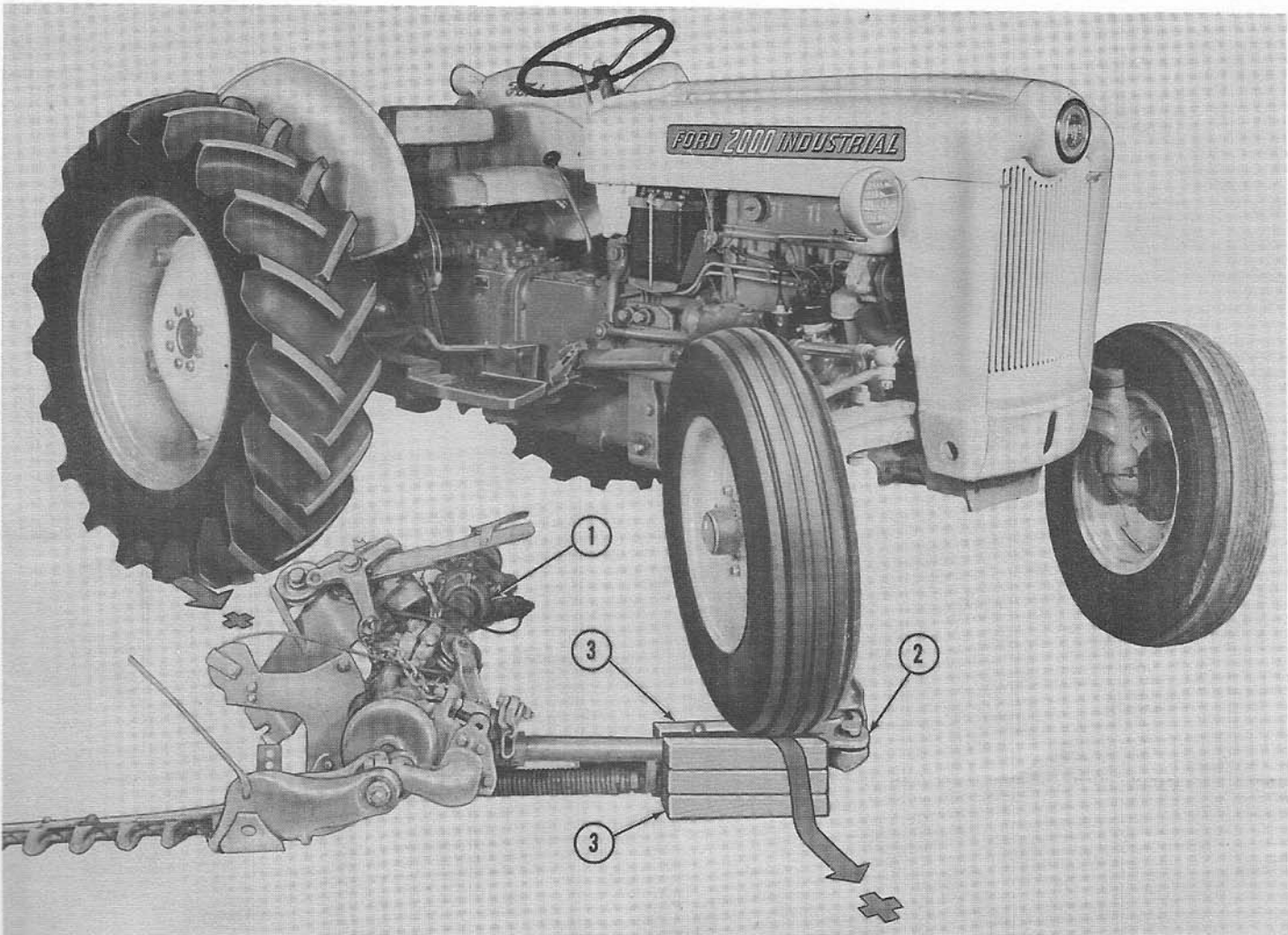

Figure 13
Positioning the Tractor Over Mower for Attaching

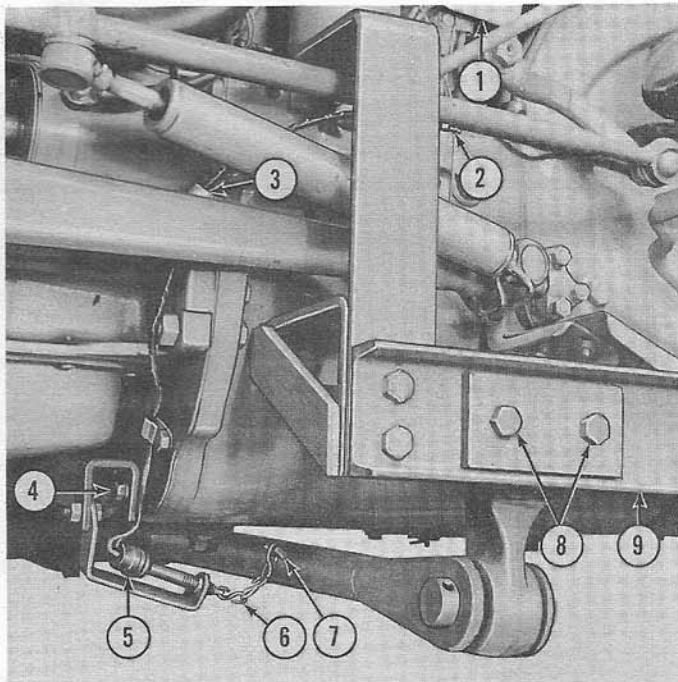

Figure 14
Dragbar and Safety Switch Attached



CAUTION: Do not place your fingers between the guards. Grasp the rear edge of the cutter bar to raise or lower by hand.

8. Adjust the tension on the dragbar balance spring (5) until the outer end of the cutter bar can be easily raised with one hand. Adjust tension on the front balance spring (6), Figure 7, until there is approximately 50 lbs. pressure on the cutter bar inner shoe.
9. Attach the lift arm extension (3) to the tractor right lift arm with the U-bolt (1) and pin (2), as shown in Figure 16.
10. Position the curb lift lever and pedestal on the three mounting bolts. Tighten the three mounting bolts securely.
11. Slip the drive belts, Figure 16, over the drive and driven sheaves.
12. Shorten the adjusting link to the minimum length. Hook the bracket of the link, Figure 8, to the right rear corner of the tractor drawbar support and insert the adjusting screw in the driven sheave housing and secure with a cotter pin. Secure the belt guard to the tractor with two bolts and flat washers.

DETACHING MOWER FROM TRACTOR

1. With the cutter bar in the transport position, disconnect the balance spring (5), Figure 15, from chain (7).

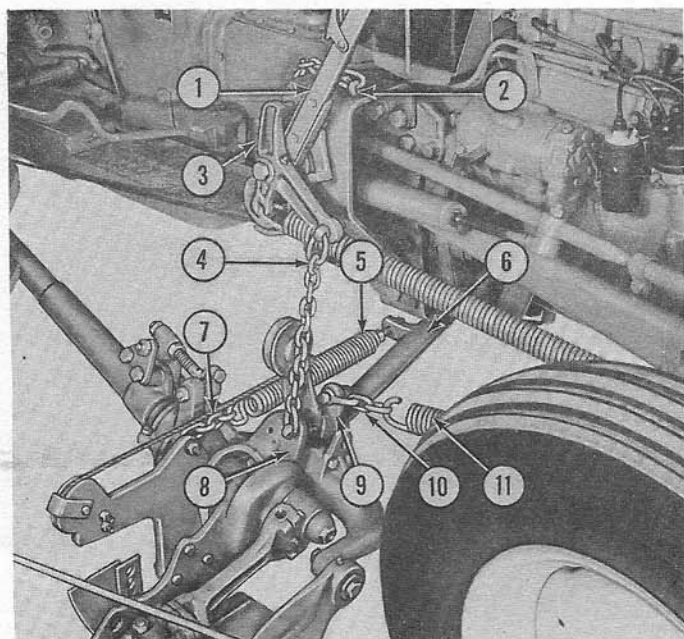

Figure 15
Curb Lift Lever Installation

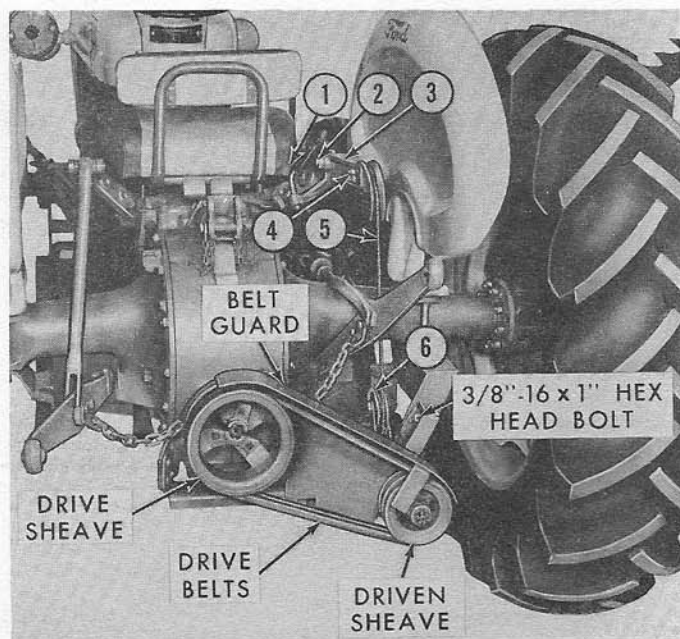

Figure 16
Drive Belts and Guard Installed

OPERATION

- Loosen bolts (8) and (14), Figure 7, until the balance spring (6) and pull spring (13) can be unhooked. Remove the axle clamp (15), bolts, and springs from the axle.
- Lower the cutter bar to the ground.
- Remove the belt guard, Figure 16. Loosen the drive belt adjusting link assembly and unhook it from the tractor drawbar support. Remove the belts.
- Remove the lift arm extension and cable from the tractor lift arm.
- Connect the right lift rod to the tractor lift arm.
- Loosen the three bolts that attach the curb lift levers and pedestal to the mounting bracket. Lift the assembly off the bracket.
- Unhook the safety switch chain (6), Figure 14, from the lug on the drag bar (7). Remove the hook and chain from the switch so it will not tangle in weeds or other debris.
- Remove the two bolts (8) that attach the drag bar (7) to the left frame rail (9).
- Remove the lynch pin and pin that secures the drive shaft housing to the rear mounting bracket. Drop the housing to the ground and free the front mounting pin (stud) from the bracket.
- Place pieces of 2'' x 4''s (3), Figure 13, on each side of the mower drag bar and turn the tractor front wheels to the right. Back the tractor slowly so the right front wheel rides over the drag bar at the 2'' x 4''s and back the tractor clear of the mower.

MAINTENANCE SUGGESTIONS

- Make a periodic check of the mower for worn parts, improper adjustments and nuts or bolts that may have worked loose.

- Replace all worn or broken parts promptly. Your Ford Tractor and Implement Dealer stocks genuine Ford Tractor and Implement repair parts. These parts are manufactured and inspected to provide high quality and accurate fit. Insist on genuine Ford Tractor and Implement repair parts.
- Keep the knife in register and properly sharpened.
- Lubricate the mower as directed in this manual. See page 4.
- Store the mower in a clean, dry place.
- When storing the mower, remove the knife, and cover it with a good rust preventive. Place the mower in a safe location to avoid possible injury to persons and animals. Thoroughly clean the entire mower, replace worn or broken parts, lubricate the mower, and cover the unprotected parts with a rust preventive.

SHIPPING INFORMATION

The Dearborn Side Mounted Mower, less cutter bar, is shipped in one carton as Bundle No. 14-233. Check the contents of the bundle against the following list and Figure 17, to make certain all parts are received.

<u>Key No.</u>	<u>Description</u>	<u>Qty.</u>
1	Pedestal Assembly	1
2	Burlap Bag of Parts & Hardware	1
3	Pulley Housing Bracket, Cable Sheave, Cable Guide	1
4	Upper Left Bracket Assembly	1
5	Elevator Lift Lever	1
6	Safety Switch Assembly	1
7	Outer Shoe Sole Assembly	1
8	Lower Left Bracket Assembly	1
9	Outer Shoe Assembly	1
10	Inner Shoe Sole Assembly	1
11	Mower Drive Assembly	1
12	Left Mounting Frame Assembly	1
13	Extension and Cable Assembly	1
14	54'' V-Belt	2
15	Grass Rod	1
16	Drive Sheave	1

ASSEMBLY

Key No.	Description	Qty.
17	Belt Guard	1
18	Assembly and Operating Manual	1
19	Right Bracket Mounting Assembly	1
20	Inner Shoe Assembly.....	1
21	Drag Bar Assembly, Cutter Bar Balance Spring Assembly, Adjusting Screw, Drag Bar Arm Assembly, Pulley Spring Assembly, Adjusting Screw, and Hinge Balance Spring Assembly wired together	1

ASSEMBLY PROCEDURE

NOTE: It is the responsibility of the Ford Tractor and Implement Dealer to assemble this implement and instruct the owner in its care, operation, and maintenance. The following instructions are provided in case of need.

1. Lay out the parts to facilitate the assembly of the mower.
2. Prepare the tractor to facilitate installation as follows:
 - a. Disconnect the lift rod from the tractor right lift arm and connect it to the brake camshaft as shown in Figure 18 with the storage hook provided. Close the hook on the brake camshaft to prevent losing it.
 - b. Set the tractor right rear wheel at the 56" center relationship. The left wheel may be set at any setting desirable for the job.

The Cutter Bar Assemblies, Models 14-61, 14-64, and 14-234, are sold separately. When purchased, either comprises an additional bundle. The shipping bundle numbers for the cutter bars are the same as the model numbers.

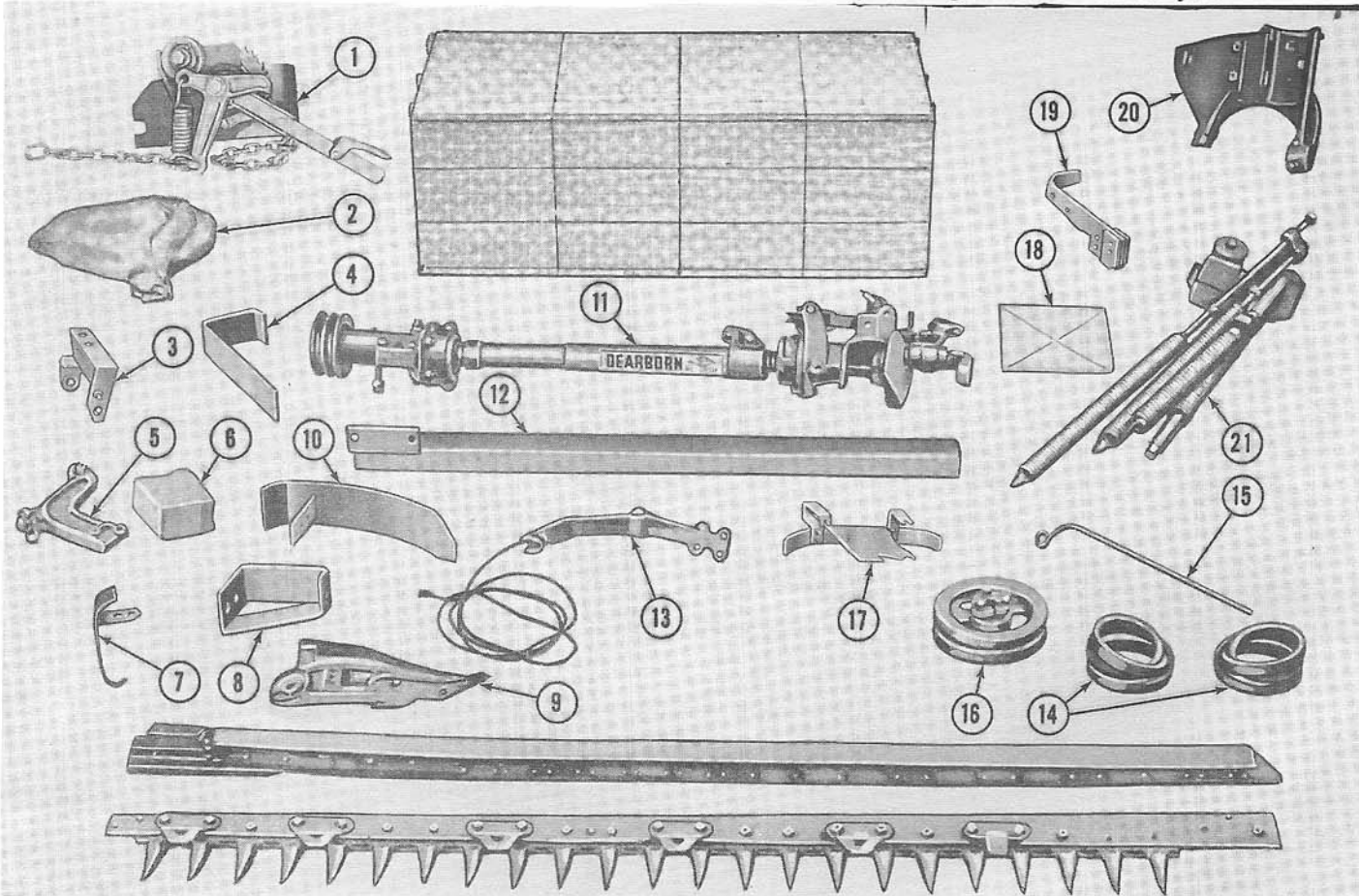

Figure 17
Dearborn Side Mounted Mower, Bundle No. 14-233

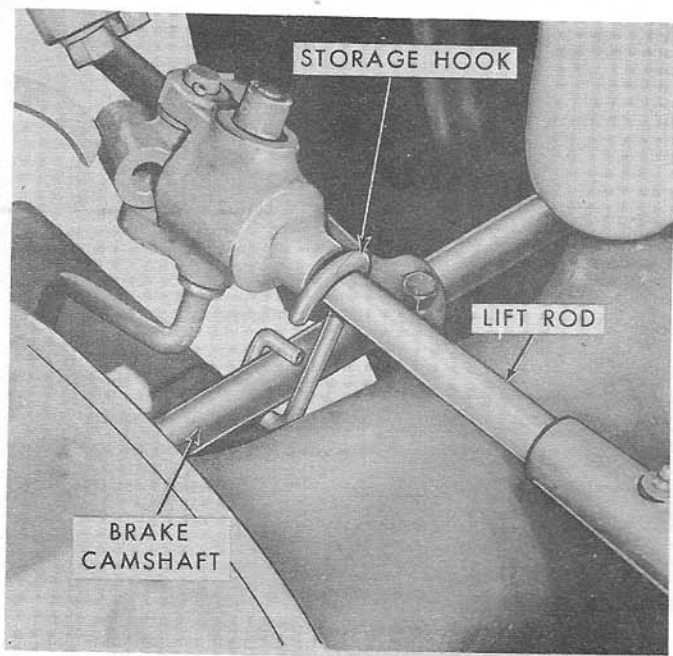

Figure 18
Lift Rod in Stored Position

3. Bolt the upper (1) and lower (2) left mounting brackets to the tractor transmission as shown in Figure 19.
4. Attach the left mounting frame to the left axle and to the lower left mounting bracket (2) as follows:
 - a. Attach the frame (4) to the lower bracket (2) at the upper hole using one bolt (3), lock washer, and nut provided.
 - b. Remove both nuts and lock washers from the left fender bolts.
 - c. Secure the mounting frame (4) to the rear axle with the two fender bolts.
 - d. Install the lower bolt (5) in the frame and secure with a lock washer and nut provided.
5. Attach the pedestal mounting bracket to the side of the transmission case with three 5/8" - 11 x 1-3/8" bolts and lock washers, and one 5/8" - 11 x 2" bolt and lock washer as shown in Figure 20.

NOTE: The 2" long bolt is the center mounting bolt.

the mounting bracket with three 5/8" - 11 x 1-3/4" bolts, flat washers, and lock washers.

NOTE: If working on a 2000 or 4000 Series tractor, cut the accelerator pedal and step plate as shown in Figure 21, to provide clearance for the pedestal mounting bracket.

7. Secure the drive housing mounting bracket to the right axle housing with the two fender bolts as shown in Figure 22.
8. Remove the tractor P.T.O. cap from the center housing. Slide the mower drive sheave onto the P.T.O. shaft. Tighten the two 1/2" - 13 x 2-1/2" square head attaching bolts, Figure 23.
9. Remove the large castellated nut (6), Figure 24, and washer from the threaded end of the drag bar (8), and remove the paint from the machined surface. Install the drag bar and tighten the castellated nut and washer until all clearance is removed; however, the hinge must be loose enough to turn when adjusting the cutter bar tilt. Secure the nut with the cotter pin as shown in Figure 24. Install a mounting stud in the drive housing.
10. Attach the cutter bar inner shoe (8), Figure 25, to the hinge assembly (2), as follows:
 - a. Remove the bearing cap (1) from the inner shoe bearing.
 - b. Position the inner shoe assembly (8) so the shaft fits on the bearing and position the bearing cap (1) over the shaft. Secure with two lock washers and bolts.

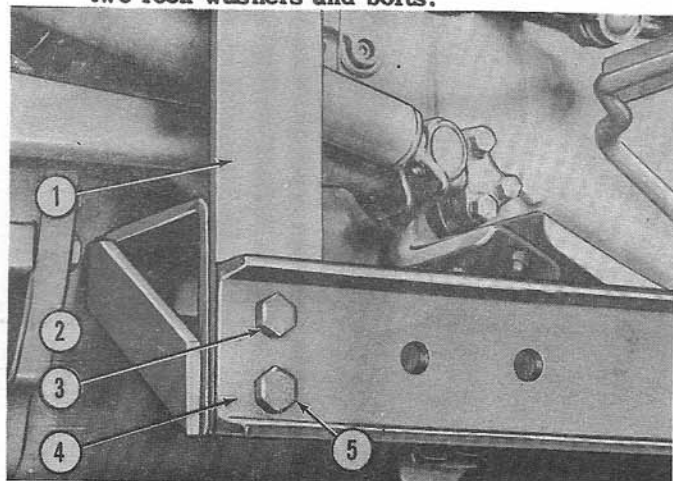

Figure 19
Lift Mounting Brackets and Frame Installed

6. Secure the pedestal and lift lever assembly to

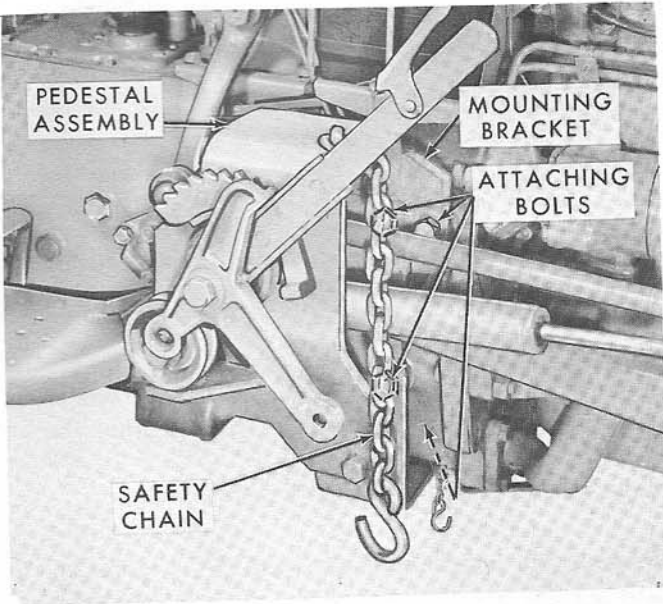

Figure 20

Pedestal Mounting Bracket Installed

- c. Insert the bushing (4) and bolt (5) through the hinge assembly and inner shoe and secure with the flat washer, castellated nut (7), and cotter pin provided.
- d. Attach the inner shoe elevating lever assembly (3) to the inner shoe (8) using three bolts (6), lock washers, and nuts.
11. Place the drive assembly in its relative position, Figure 13, under the tractor. Lift the drive housing into place and slide the stud into the bearing at the front end of the mounting bracket. Align the rear of the housing with the mounting bracket and install the attaching pin and linch pin.
12. Attach the drag bar (7), Figure 14, to the frame (9).
13. Assemble the cutter bar (14), Figure 26, to the inner shoe (3), as follows:
 - a. Slide the knife (20) into the cutter bar (14) and position the cutter bar over the inner shoe assembly.
 - b. Attach the cutter bar (14) to the inner shoe (3), using the bolt, flat washer, lock washer, and nut (11).
 - c. Attach the rear guide plate (16), shims (18), and knife guide assembly (19), to the inner shoe and cutter bar, using the two bolts (6),

flat washers, lock washers, and nuts.

- d. Attach the inner shoe wear plate, shims, and knife guide assembly (15), to the inner shoe and cutter bar, using the two bolts (12), flat washers, lock washers, and nuts.
- e. Position the inner shoe sole under the inner shoe and insert a bolt (4) through the forward end of the sole and the inner shoe assembly. Position the grass rod (1) over the bolt (4) and secure with a flat washer, lock washer, and nut. Secure the rear of the sole assembly (13) to the desired hole of the inner shoe with the bolt (5), lock washer, and nut provided.
- f. Attach the Pitman arm (2) to the knife head (17). Add or remove shims (7) between the socket halves (8) until the proper fit on knife head (17) is obtained. Secure the socket (8), shims (7), washers, and Pitman arm (2), to the knife head, using two 1/2" x 2-1/4" bolts (10), lock washers, and nuts.

14. Attach the outer shoe (6), Figure 9, as follows:

- a. Attach the outer shoe (6), to the cutter bar (5), using two 7/16" x 1-1/2" plow bolts (7), lock washers, and nuts provided.
- b. Insert the hooked end of the outer shoe sole (8) in the hole provided in the forward end of

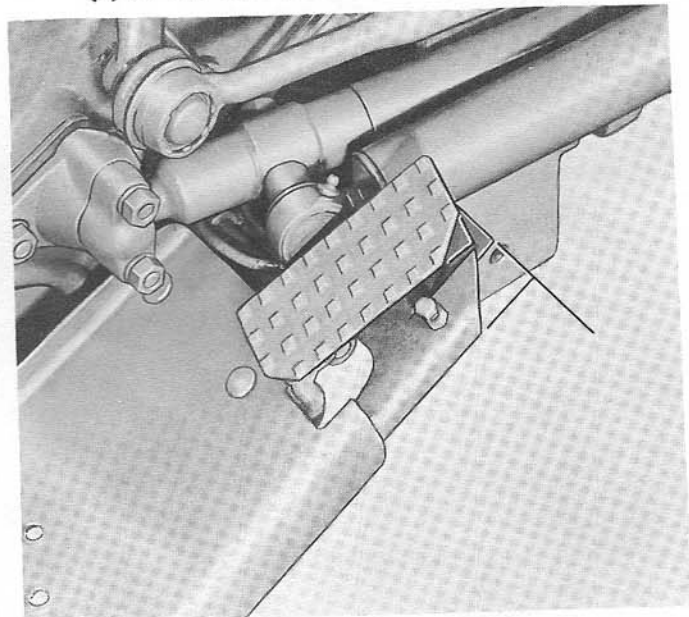

Figure 21

Accelerator Pedal Modification for 2000 and 4000 Series Tractor

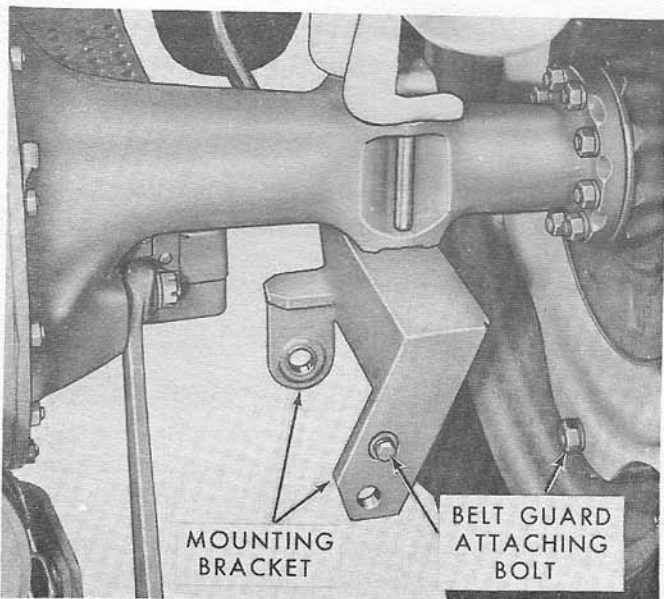

Figure 22

Drive Housing Mounting Bracket Installed

the outer shoe assembly (6). Attach the outer shoe sole (9) to the outer shoe assembly by inserting a 7/16" x 2-1/4" carriage bolt (10), in the desired hole in the outer shoe or outer shoe sole assembly. Secure with a lock washer and nut.

15. Attach the curb lift lever chain (4), Figure 15, to the hinge (8).
16. Position the axle clamp (15) over the axle as shown in Figure 7. Hook the balance spring (6) on the curb lift arm (3) with the hook toward the



Figure 23

Drive Sheave Installation

tractor. Thread bolt (8) into the balance spring until the coils start to open. Hook the pull spring (11), Figure 15, into chain (10) and thread the bolt into it.

17. Raise the outer end of the cutter bar by hand and hook the chain (7), Figure 15, to the drag bar balance spring (5), and lower the cutter bar to the ground.



CAUTION: Do not place your fingers between the guards. Grasp the rear edge of the cutter bar to raise or lower by hand.

18. Adjust the tension on the drag bar balance spring (5), Figure 15, until the outer end can be easily raised with one hand. Adjust tension on the front balance spring until there is approximately 50 lbs. pressure on the cutter bar inner shoe.

NOTE: When the mower is raised, the hook of spring (6), Figure 7, should be slightly ahead of sheave (9) to prevent interference.

19. Attach the lift arm extension (3), Figure 16, to the tractor right lift arm with the U-bolt (1) and pin (2).

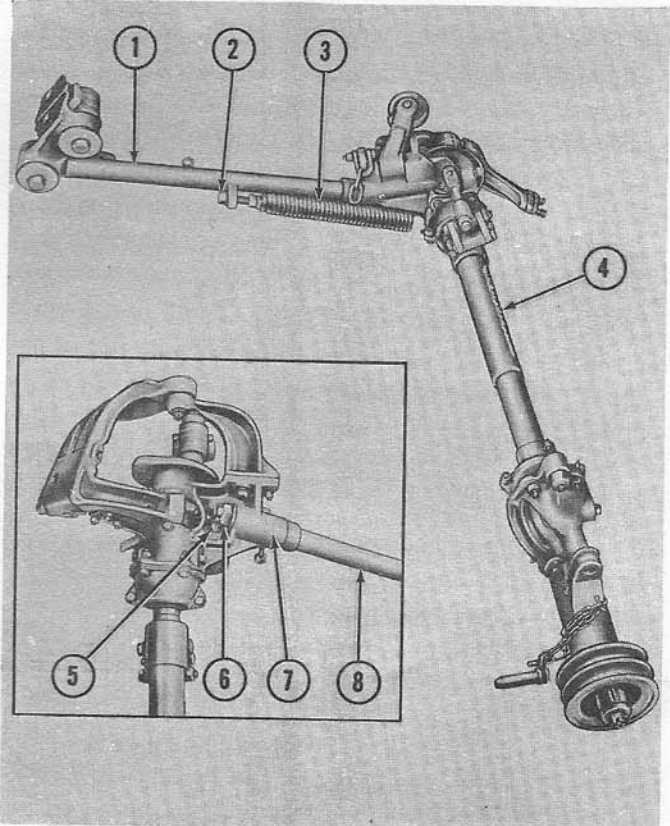

Figure 24

Drive Assembly Ready for Installation

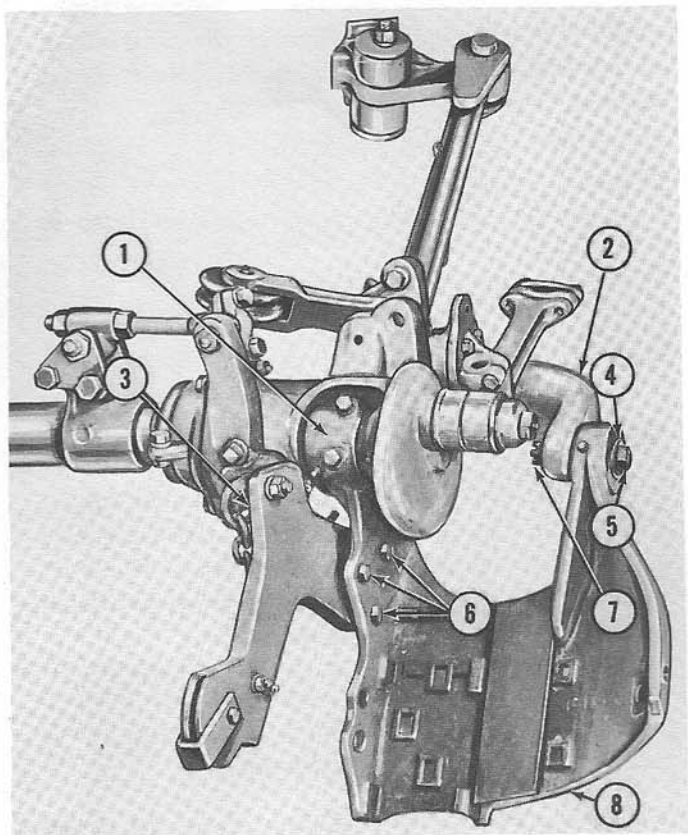

Figure 25

Inner Shoe and Elevating Lever Attached

20. Lower the tractor hydraulic touch control lever to its lowest position.
21. Thread cable (5) through pulley (6), Figure 16, and through (4), (5), and (9), Figure 7. Place the loose end of the cable over the elevating lever (11) as shown in Figure 7. Draw the cable tight, then install and tighten clamp (10) enough to raise the cutter bar and still permit the cable to slip when the bar is in the maximum "UP" position.
22. Carefully raise the cutter bar to its maximum "UP" position with the tractor hydraulic system. Allow the cable to slip until the tractor lift arms are fully raised, then tighten clamp (10) securely to hold the cable.

NOTE: This procedure will allow the lift arms to raise to their full extent without overloading and damaging the hydraulic system, cable, or mounting parts.

23. Slip the drive belts, Figure 16, over the drive and driven sheaves. Shorten the adjusting link to the minimum length. Hook the bracket, Figure 8, onto the right rear corner of the tractor drawbar support and insert the adjusting screw in the driven sheave housing and secure with a cotter pin. Turn the adjusting sleeve to tighten the belts

to 1/4" deflection midway between the sheaves. Tighten the lock nut against the sleeve.

24. Loosen the upper right P.T.O. shaft attaching bolt. Install the 3/8" - 16 x 1" hex head bolt and flat washer on the mounting bracket. Secure the belt guard to the tractor with these two bolts.
25. Attach the safety switch harness as follows:
 - a. Disconnect the battery ground cable from the tractor.
 - b. Attach the safety switch and mounting brackets (5) to the engine with the existing engine-to-transmission case bolt (4), Figure 14. Connect the safety switch chain to the drag link (7).
 - c. Attach the wire lower clip (3) to the engine-to-transmission case bolt. Attach the wire upper clip (2) to the steering housing with the right forward steering housing-to-transmission bolt.
 - d. Working through the opening in the top of the hood, insert the push button switch in the hole in the panel, Figure 27, and secure with the knurled nut.

NOTE: If the tractor is equipped with a Select-O-Speed Transmission, the push button **must** be installed on the left side.

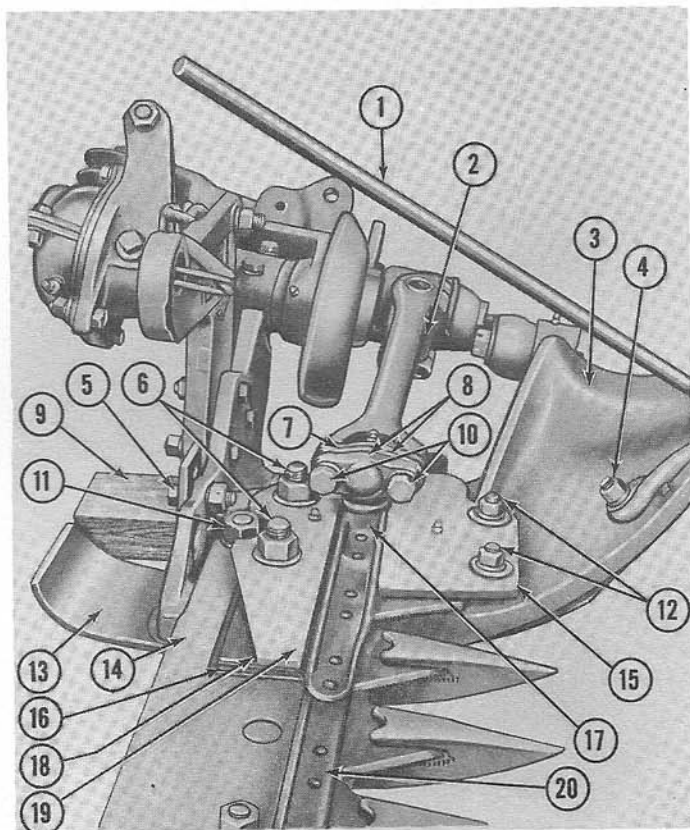

Figure 26

Cutter Bar Installation

Gasoline and LP-Gas Tractors

1. Disconnect the double red and white wire from terminal (3), Figure 28. Connect one of the mower harness leads to terminal (3).
2. Connect the double red and white wire that was disconnected from terminal (3), to the other mower harness lead with the nut and bolt that was furnished.
3. Connect plugs (5), to receptacles (6).
4. Connect the battery ground cable to the tractor.

Diesel Tractor

NOTE: Prior to installing the mower cut-off switch on a Ford Diesel Tractor, it will be necessary that the injection pump has previously had the new type cover, Part No. B9NN-9A594-A installed at an authorized station. The new cover contains a solenoid for electrically shutting off the diesel fuel when the mower strikes an obstruction that may cause damage to the mower.

1. Connect one of the mower harness leads to ter-

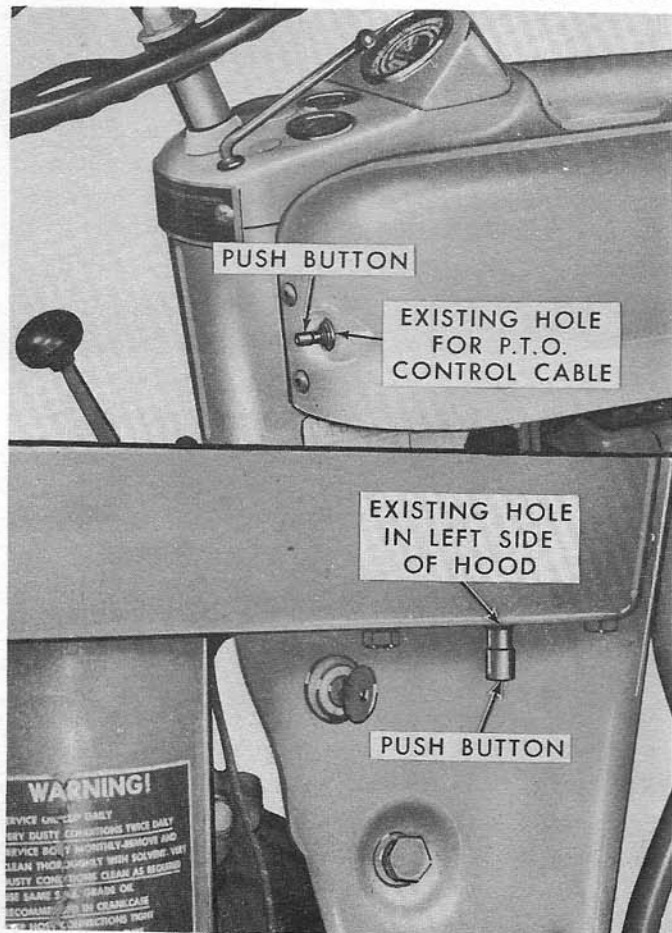

Figure 27
Push Button Installation

terminal (3), Figure 28.

2. Connect the other mower harness lead to the wire connecting the fuel injection pump.
3. Connect plugs (5) to receptacles (6).
4. Connect the battery ground cable to the tractor.

ACCESSORIES

A Tilt Lever and a P.T.O. Extension, Figure 29, are available for use with the Dearborn Side Mounted Mower. The tilt lever permits the operator to adjust the tilt of the cutter bar from the tractor seat. The P.T.O. extension permits operation of other P.T.O. powered equipment in conjunction with the side mounted mower. It also makes it unnecessary to remove the mower drive sheave to operate other equipment after the mower has been removed.

A Swathboard and a Grass Stick are available to mount on the end of the cutter bar, Figure 32, for cutting clean edges.

INSTALLATION

Tilt Lever

1. Secure the tilt lever operating rod to the ball joint with cap screws (3), Figure 30.
2. Connect the tilt lever (1) and ratchet (2) to the

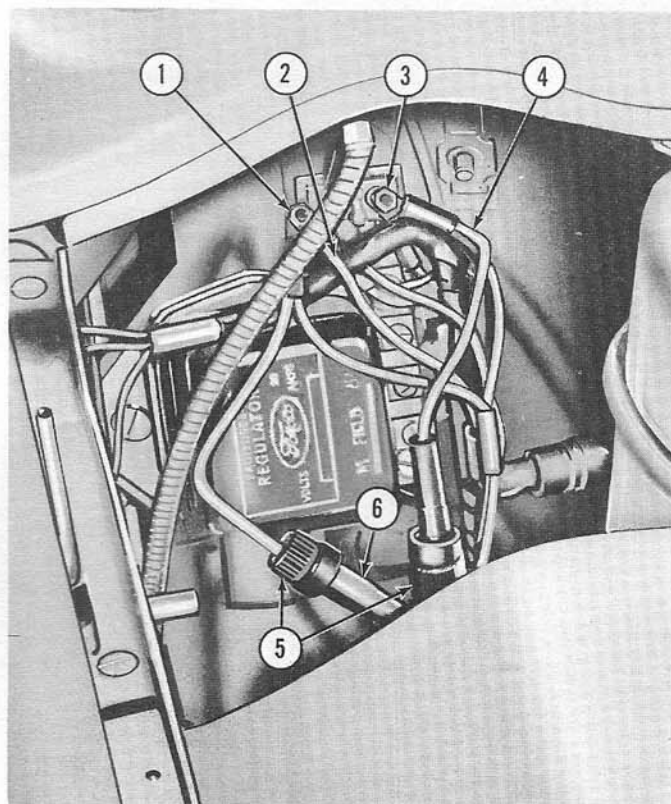

Figure 28
Safety Switch Wire Installation

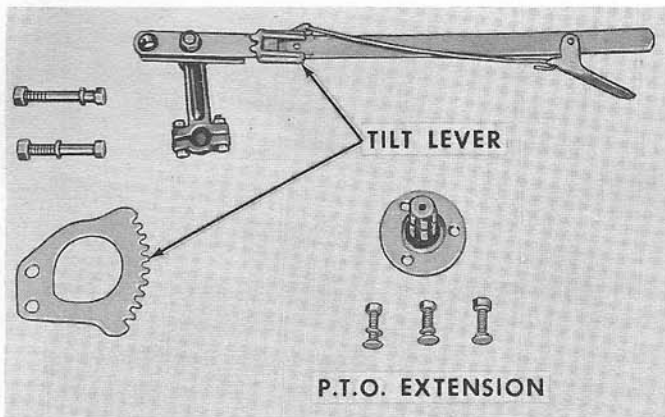

Figure 29

Dearborn Side Mounted Mower Accessories

drive shaft mount (5) with bolts (4).

P.T.O. Extension

1. Hold the P.T.O. extension in place on the mower drive sheave.
2. Install the carriage head attaching bolts as shown in Figure 31. Tighten the nuts evenly and alternately.

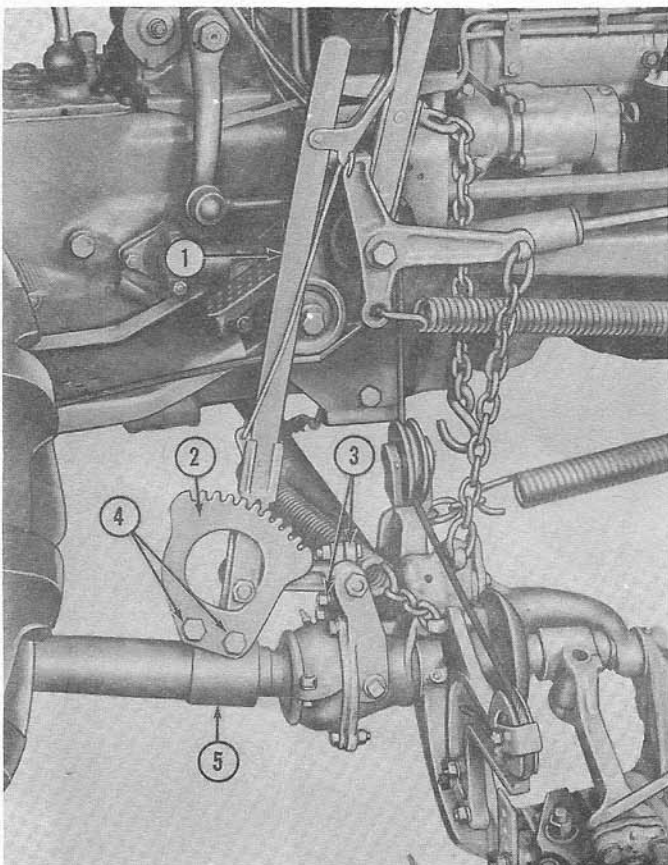

Figure 30
Tilt Lever Installed

Swathboard

Attach the swathboard (3), Figure 32, to the outer shoe assembly, using one 1/2" x 2-3/4" drilled carriage bolt (11), flat washer, spring, flat washer, nut and cotter pin.

Grass Stick

Attach the grass stick (1), Figure 32, to the swathboard, using one 5/16" x 1-1/4" carriage bolt (2), one 5/16" x 2-1/2" carriage bolt (4), and two flat washers, lock washers, and nuts.

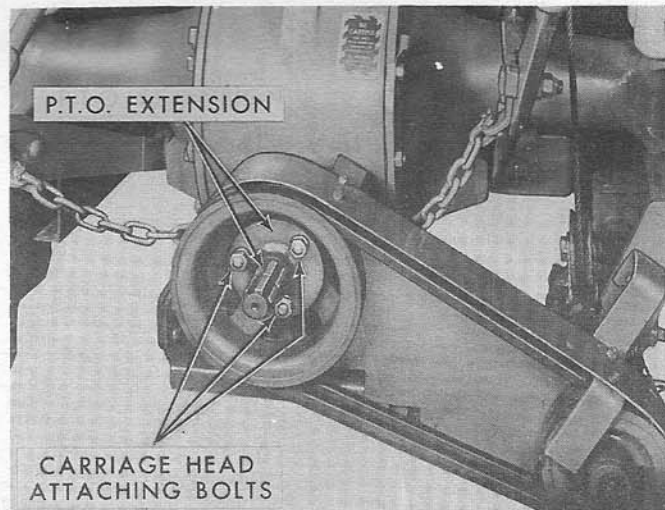

Figure 31
P.T.O. Extension Installed

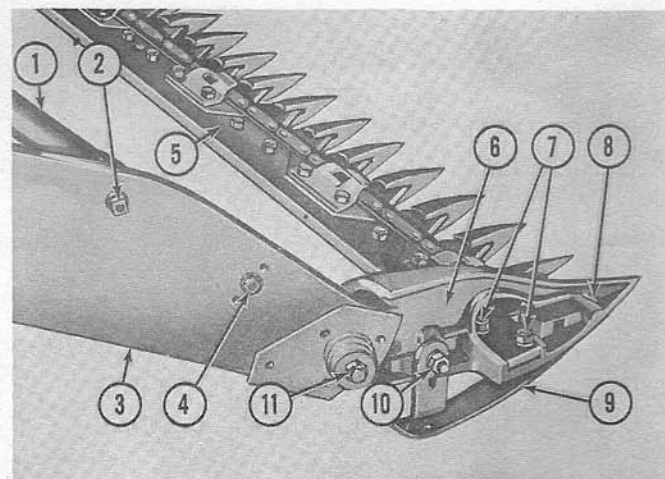

Figure 32
Swathboard and Grass Stick Installed

PRE-DELIVERY

PRE-DELIVERY CHECK LIST

Owner's Name _____

Address _____

Mower Model _____ Serial No. _____

AFTER IMPLEMENT ASSEMBLY

- Machine lubricated thoroughly as outlined in lubrication chart.
- All bolts checked for tightness.
- All cotter pins and pins in place.
- Drive belts checked for proper deflection.
- Cutter bar ground pressure adjusted.
- Cutter bar lead checked.
- Cutter bar break-out spring adjusted, and safety switch checked for positive ignition or fuel cut-out.
- Knife assembly checked for register and shear.
- Belt guard in place.

AT TIME OF DELIVERY

- Operation and adjustments of implement explained to owner as outlined in the Assembly and Operating Manual.
- All lubrication fittings pointed out to owner.
- Safety rules and precautions explained to owner.
- Procedures for attaching and detaching implement on tractor explained to owner.

DATE _____

DEALER SIGNATURE _____



"Ford Motor Company, whose policy is one of continuous improvement, reserves the right to make changes in design and specifications at any time without notice and without obligation to modify units previously built."